

FEATURES

- 10/12 dBm P1dB/PSAT
- Full E-band coverage
- 20 dBm OIP3
- 15 dB gain

TYPICAL APPLICATIONS

- Point-to-point communication
- Instrumentation
- Fiber over radio
- 77 GHz radar

DESCRIPTION

gANZ0012 is a Medium Power Amplifier (MPA) in the E-band suitable for point-to-point communication. The MPA features 16 dB P1dB and very flat frequency response. Furthermore, the MPA has high gain, high linearity and low input/output return loss.

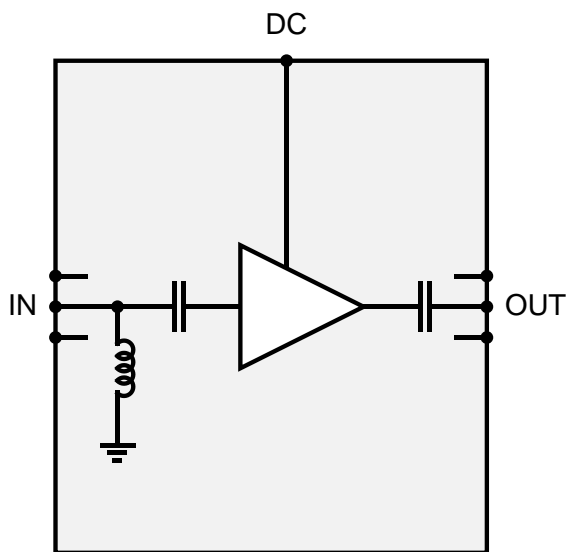

Figure 1. Block diagram of the MPA.

ELECTRICAL PERFORMANCE

Table 1. Electrical performance $T_A=25^\circ\text{C}$

Parameter	Min	Typ	Max	Unit
Frequency	71(65)		86 (90)	GHz
Gain		13		dB
NF		6		dB
P1dB	7	10	13	dBm
PSAT	9	12	15	dBm
OIP3	17	20	23	dBm
PAE		TBD		%
Input return loss		4		dB
Output return loss		10		dB
Power consumption		200		mW

MEASURED PERFORMANCE

The chip has been measured on-wafer using CW and 2-tone input test signals. The MPA uses typical bias settings if not specified differently.

Table 2. Test conditions

Parameter	Setting
RF input power	-25 dBm/tone
RF input frequency	81 GHz
Frequency separation	10 MHz
Temperature	25°C

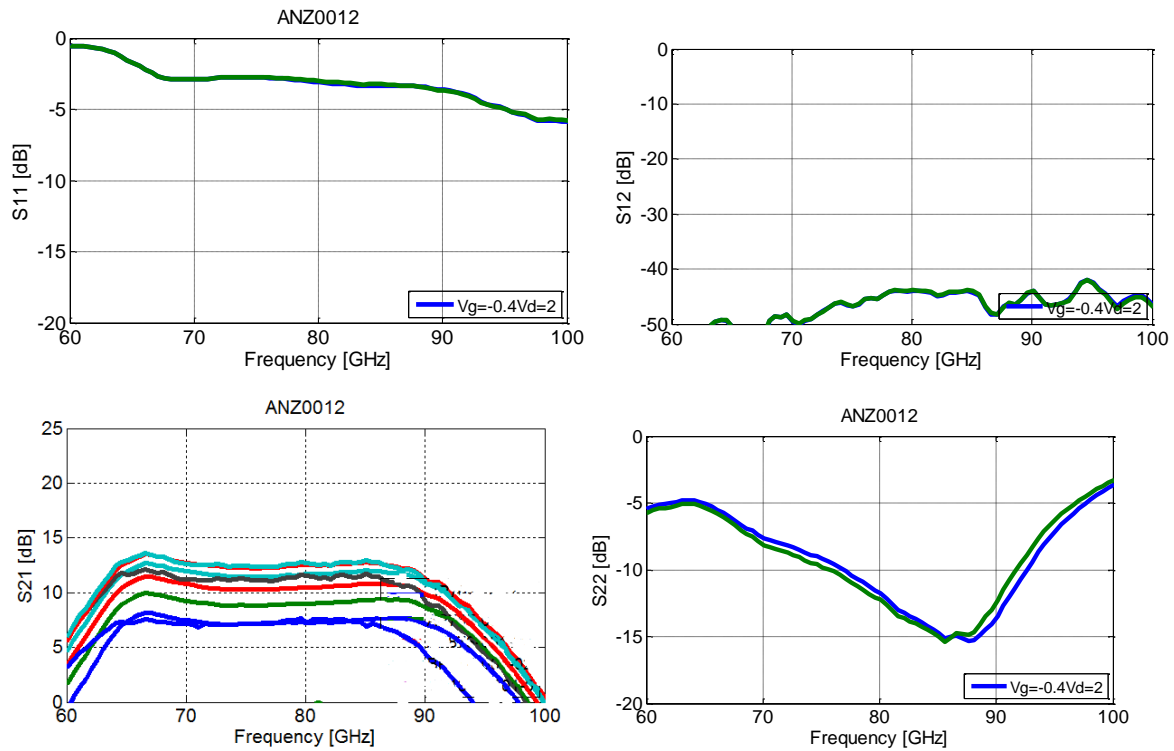

Figure 2. Small signal response from 60-100 GHz at nominal bias. (Upper left): Input matching. (Upper right): Reverse isolation. (Lower left): Small-signal gain. (Lower right): Output matching.

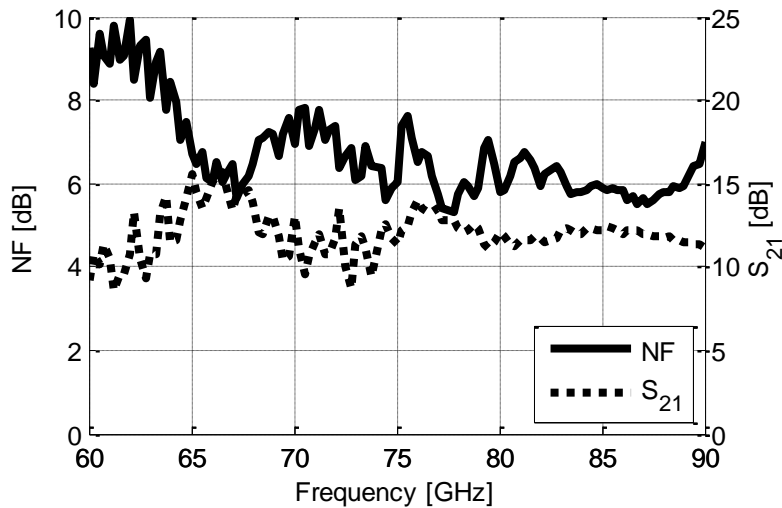

Figure 3. (Left): NF vs freq

RECOMMENDED OPERATING CONDITIONS

Bias should first be applied to the gates (VG...) followed by the drains (VD...). The gate voltages must be adjusted within the min/max range indicated in Table 3-Table 5 to obtain the specified drain currents. The drain currents are stated with no input signal.

Table 3. Electrical settings on connector P1

Connector P1	Pad No.	Bias settings (V/mA)			I/O
		Min	Typ	Max	
VD	1	2	3 / 75	3.3	Input
NC	2				NC
GND	3				Ground
VG2	4	-0.6	-0.4	-0.2	Input
VG2	5	-0.6	-0.4	-0.2	Input

Table 4. Electrical settings on connector P2

Connector P2	Pad No.	Interface	I/O
GND	1		Ground
RF_OUT	2	$Z_0 = 50 \text{ Ohm}$, AC coupled	Output
GND	3		Ground

Table 5. Electrical settings on connector P3

Connector P3	Pad No.	Interface	I/O
GND	1		Ground
RF_IN	2	$Z_0 = 50 \text{ Ohm}$, AC coupled	Input
GND	3		Ground

ABSOLUTE MAXIMUM RATINGS

Table 6. Absolute maximum ratings

Gate-source voltage	-2 to +0.7 V
Drain-source voltage	4.5 V
Gate-drain breakdown voltage	8 V
ID	100 mA
RF input power	+15 dBm
Operating temperature	-40 to + 85°C
Storage temperature	-65 to +150°C

OUTLINE DRAWING

Mechanical drawing with pad locations is also available in dxf-file format on the web. The substrate thickness is 50 μm (GaAs).

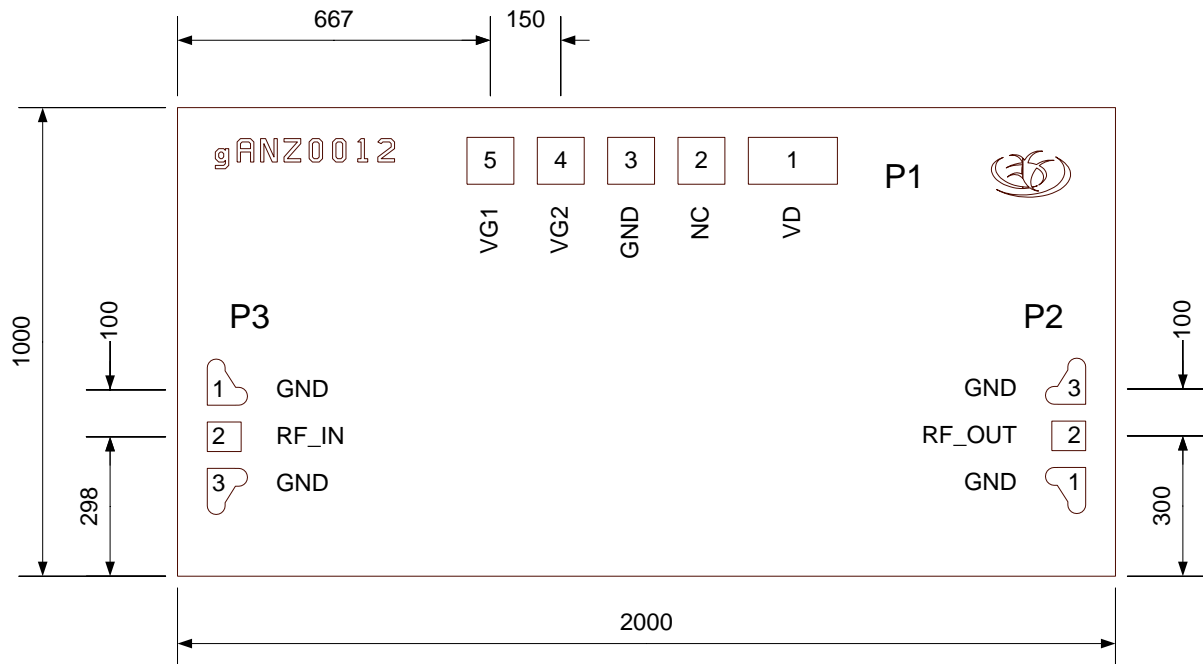

Figure 4. Outline drawing of the MMIC. Dimensions are in μm .